

PISTOL SCALING HAMMERS

116

MODEL
N-3RP



Pistol Scaler Backhead Assembly

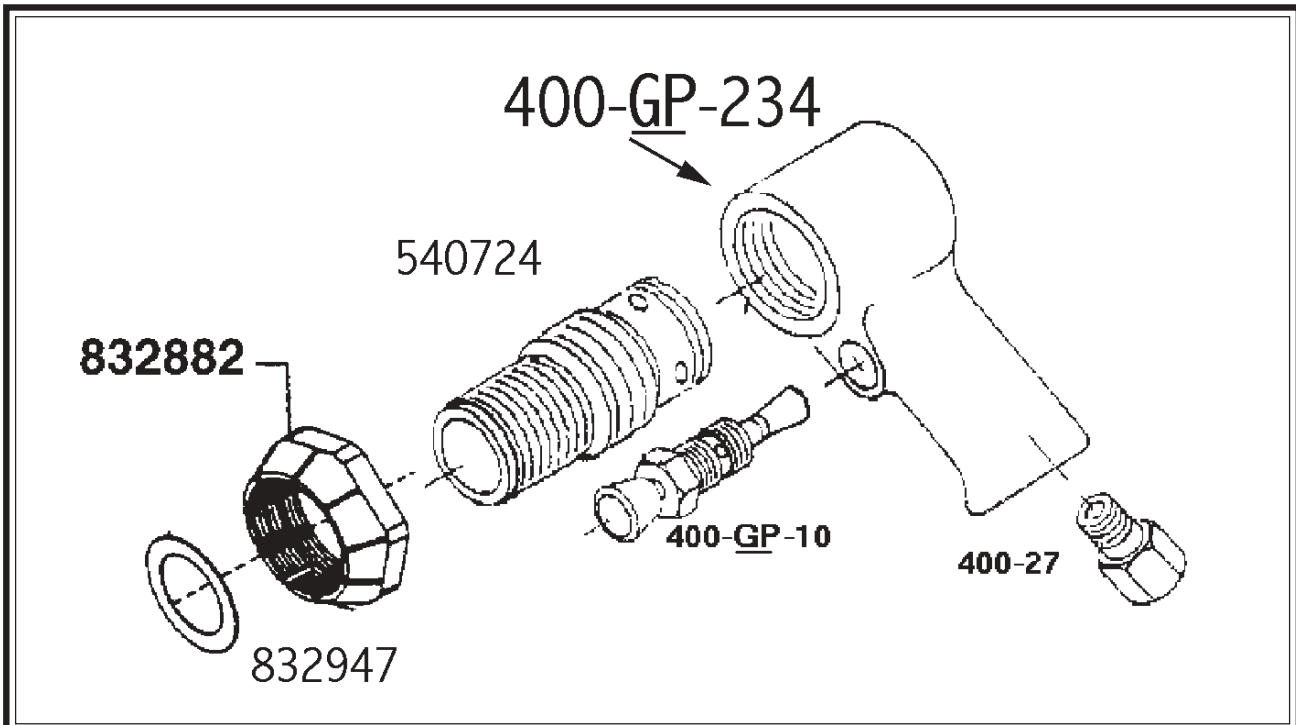

Updated 1/30/2004

HENRY AIR TOOLS

<u>PART NO</u>	<u>NAME OF PART</u>	<u>QUAN.</u>	<u>PART NO.</u>	<u>NAME OF PART</u>
831090-A	Barrel (SOLID)(includes 832700)	1	834779	Needle Tube (Round)
831090	Barrel(Includes 832700,832963 and 842801)(Replaceable Nose)	1		<u>OPTIONAL PART NOT SHOWN</u>
832126	Valve Block Dowel Pin	1	834024	Needle (7" Length) 19 Required
832173	Valve Block Button	1		<u>SUB-ASSEMBLIES</u>
832196	Valve	1	831109	Valve Block Assembly COMPLETE
832373	Plunger	1	831322	Round Needle Front End Sub (Part Nos.834043,834044,834045 834046,834779)
832508	Valve Block	1		
832554	Retainer Clip	1		
832700	Barrel Sleeve	1		
832956	Retainer	1		
833527	Retainer Buffer	1		
834043	Needle (5")	19		
834044	Needle Holder Spring	1		
834045	Needle Driver	1		
834046	Needle Holder	1		

Pistol Scaling Hammers (CONTINUED)

MODEL
N-3RP

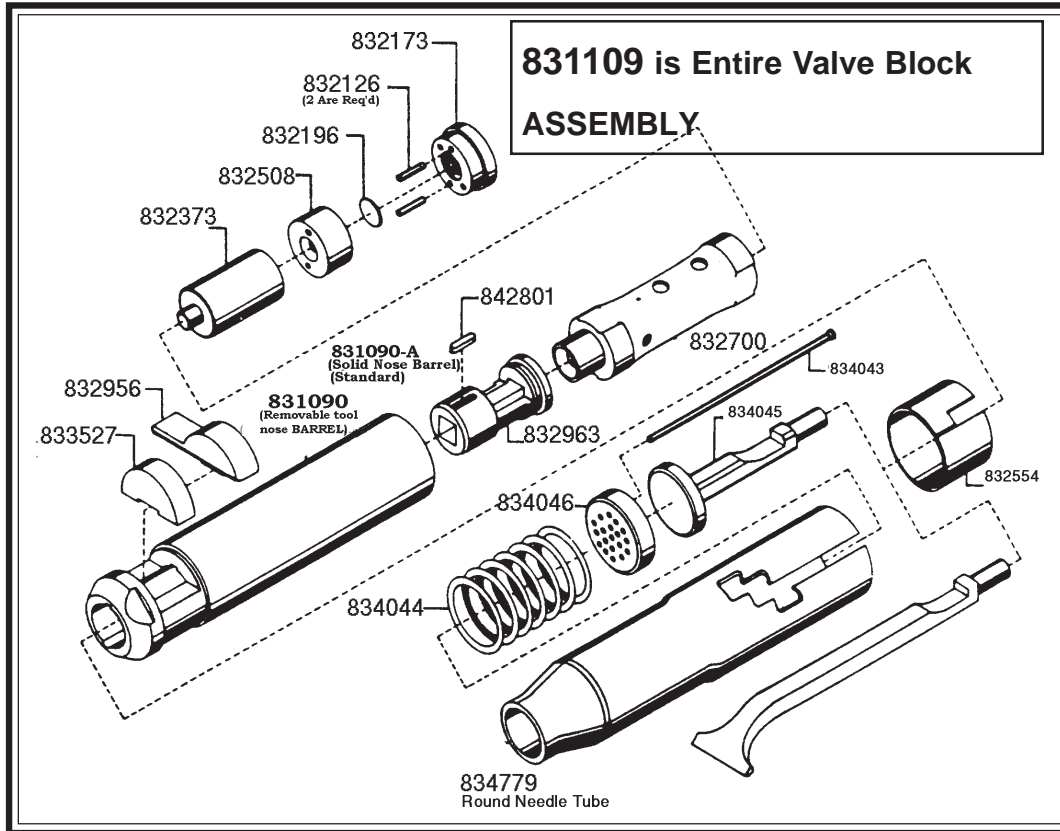

CHISELS AVAILABLE

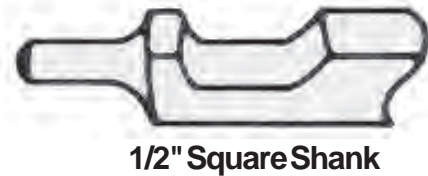
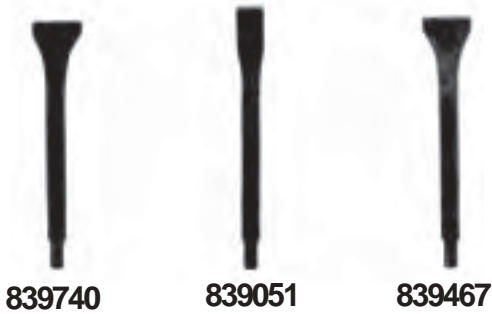

SPECIFICATIONS

Part No.	Description	Cutting Edge Width	Length
839051	D-200-7 1/2 Narrow Chisel	3/4"	7 1/2"
839341	D-200-12 Narrow Chisel	3/4"	12"
839335	D-200-18 Narrow Chisel	3/4"	18"
839467	B-200-7 Wide Chisel	1 3/4"	7"
839299	C-200-12 Angle Chisel	1 3/4"	12"
839334	C-200-18 Angle Chisel	1 3/4"	18"
839050	C-200-7 Angle Chisel	1 3/4"	7 1/2"

*Other types of chisels also available.