

SERVICE INSTRUCTIONS

76

This tool is designed to operate on 90 psig (6.2 bar) maximum air pressure with 1/4" (8 mm) hose. Do not use a grinder without recommended wheel guard. Do not use any wheel for which the operating speed listed is lower than the actual free speed of the Grinder.

SAFETY

1. Before operation check spindle speed with a tachometer. If the RPM exceeds the rated speed stamped on tool, servicing is required. 2. Inspect grinding wheels for bends, chips, nicks, cracks or severe wear. If the wheel has any of these, or has been soaked in liquids do not use. On brushes check for loose wires that may fly off in operation. 3. Start new grinding wheels under a steel bench. Run at full throttle for one minute. Defective wheels usually come apart immediately. When starting a cold wheel apply to work slowly, allow wheel to warm gradually. 4. Model 4402RAC grinders equipped with built in collets are intended for mounted wheels, points and carbide burrs. They are not guarded for type 1 wheels. If you have a type 1 wheel application, please purchase a guard (4504, 4505, etc.). 5. The Model 4402RA Grinders are equipped with a guard from the manufacturer. A guard is not needed for: a.) mounted wheels two inches (50 mm) or smaller; b.) grinders used for internal work, while within the work being ground. 6. At least one-half of the mandrel length (i.e. mounted wheel, burr, etc.) must be inserted into the collet. Secure collet chuck tightly. 7. Safety levers are available from the manufacturer. (402-26). 8. Before mounting or removing a wheel, disconnect grinder from air supply. The wheel should fit properly on arbor, do not use bushings or wheel flanges to adapt a wheel to any arbor unless recommended by the manufacturer. (Wheel flanges should be at least 1/3 the diameter of the grinding wheel.) 9. Wear safety goggles and other protective clothing. Continuous exposure to vibration may cause injury to your hands and arms. (See regulations.) 10. Properly maintained air tools are less likely to fail or cause accidents. If tool produces an unusual sound or vibrations repair immediately.

DISASSEMBLY

PLEASE NOTE: The brass spacers that were installed by the factory are necessary for this tool to operate efficiently. When disassembling this tool examine how spacers are arranged. They must be installed exactly the same way. Failure to do this will cause improper gear spacing, which causes pre-mature tool failure.

1. Disconnect air & remove all wheels and accessories. 2. Secure anglehead in vise on dead handle boss. Unscrew and remove case (402-132) **Never squeeze anglehead (404-1) in vise.** This will distort bearings and ruin gear alignment. 3. Remove deflector (410-G-17-S). 4. Pull motor from right angle head. Be careful to note location of shims. 5. Remove snap ring (404-39), wafer (404-38), O-ring (594016), and snap ring (592016). (Some of these may not be present). 6. Install brass or aluminum jaws in vise. Grasp the O.D. of cylinder (400-2-G) and end plate (404-19). Using a 3/16" punch, tap spindle out rear bearing (404-9) 7. Remove cylinder, blades (400-6). 8. With rotor (400-5) still on spindle (404-14), grasp the rotor in vise snugly and remove pinion gear (405-10). 8. Remove rotor (400-5) Remove key and front thrust plate (400-7). 9. Press bearing (400-11) off of spindle. 10. Secure angle head in vise and unscrew cap (404-2). 11. Remove from vise and tap on spindle with a plastic hammer The spindle assembly and spring washers (404-6) will slide out. 12. Clamp flats of spindle (405-17) in vise. Using a plastic hammer, tap evenly on O.D.

MODELS

4402 RA
4402 RAC
4402 RAS
4402 RASC
4402 RAK
4402 RASK

of bearing cap until free of bearing (404-3). Note position of shims. Using a 9/64" T-Handle hex wrench unscrew (591028) screw. [(NOTE: Some older models have a snap ring (405-16) to be removed instead of a screw)] 13. Press bearing (404-3) off spindle. Support bearing (404-7) and press spindle through with 1/4" punch. This will remove gear (405-10) and bearing (404-7). 15. Remove key (404-4).

ASSEMBLY

Support front bearing (400-G-11) on drill block. Press spindle (404-14) through bearing until it bottoms on shoulder. 2. Slide front thrust (400-7) over the spindle and onto front bearing. Place key (400-10) into keyway in spindle. Slide rotor down over shaft. 3. Grasp rotor in vise snugly and replace pinion gear (405-10) and wrench firmly. 4. Support bearing and pinion gear in downward position. Place five blades (400-6) in slots. Slip cylinder (400-2-G) over rotor. Install rear thrust (404-19) locating cylinder pin in small hole of rear thrust plate (404-19). 5. Place bearing (404-9) in rear thrust and tap into place with suitable bearing driver. Using pliers place snap ring (592016) in spindle groove. [(May be snap ring (404-39)] 6. Support bearing (404-7) on inner race. Press spindle (405-17) through bearing until it bottoms on shoulder. 7. Install key (404-4) and line up with keyway of ring gear (405-10). Support gear on inner diameter and press spindle through. Replace gear spacer ring (405-15) on spindle. 8. Support threaded end of spindle and press on bearing (404-3). Tighten screw (591028) into end of spindle. Press spindle assembly into cap (404-2) Grease gear. 9. Install spring washers (404-6) into angle head (404-1). 10. Install spindle assembly into angle head housing, secure in vise and tighten cap (404-2). 11. Re-Locate angle head in vise so that the motor can be installed vertically. 12. Replace shim (404-20) exactly as it was originally installed. 13. Jiggle greased pinion assembly into angle head while turning spindle (404-5) so that gears mesh. Tap lightly on rear of motor to insure that is fully seated. 14. Install exhaust deflector (410-G-17-S). Place O-ring (400-51) on motor case (402-132) and screw onto angle head. The deflector should be snug, but can be turned. Place a few drops of oil into motor inlet. 15. To check throttle valve, unscrew plug (869311) and lift out spring and valve. Replace O-ring if worn. 16. Replace guard on tool.

17. CHECK RPM WITH TACHOMETER. TOOL MUST RUN AT OR BELOW SPEED THAT IS STAMPED ON TOOL.

Updated 1/30/2004

HENRY AIR TOOLS



Model 4402 RAS



Model 4402 RAC

MODELS
4402 RA
4402 RAC
4402 RAS
4402 RASC
4402 RAK
4402 RASK

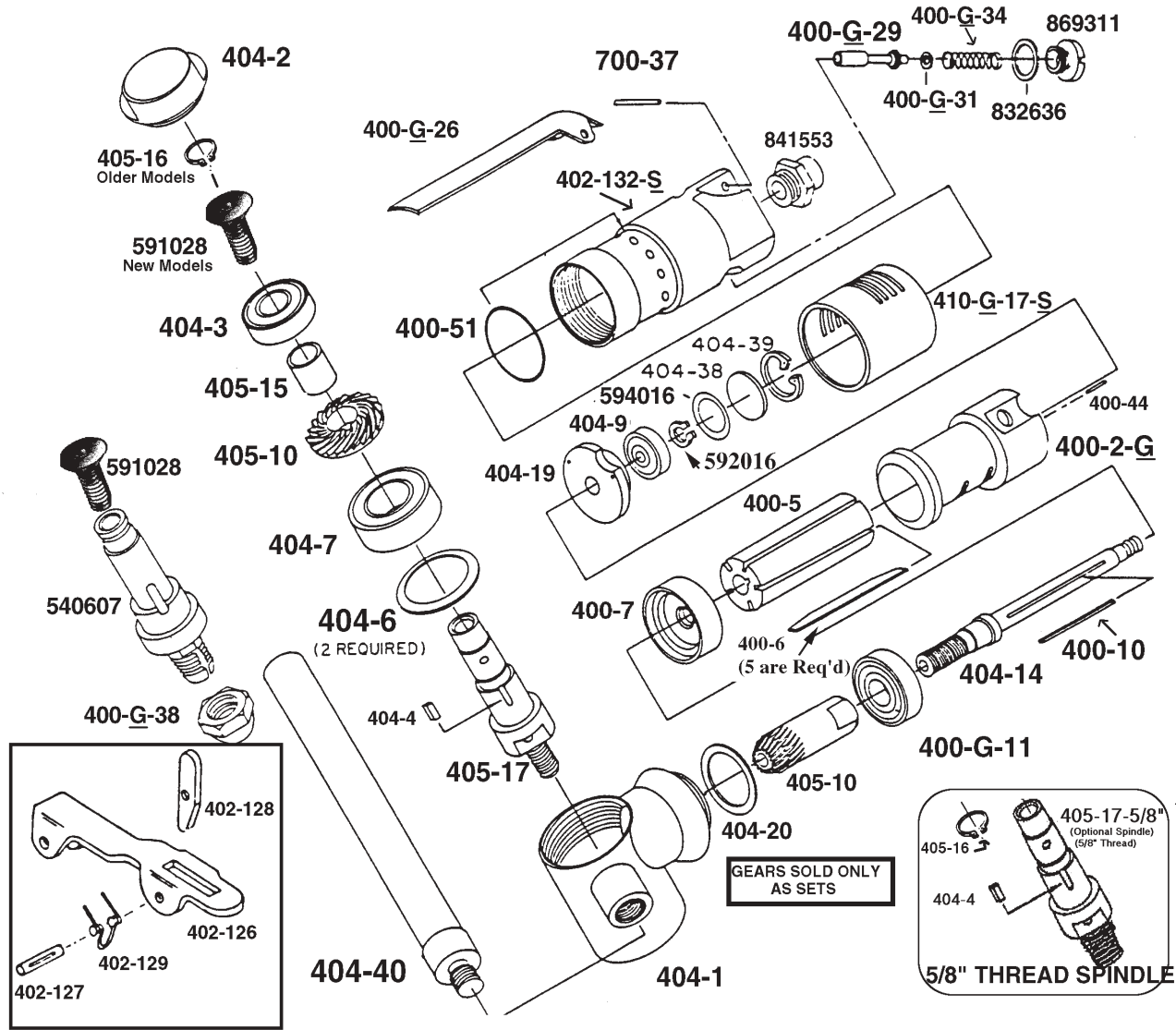

ACCESSORIES

